

8/S4
v 3.3 (en)

AIR CURTAINS

GRAND, GRAND CASSETTE

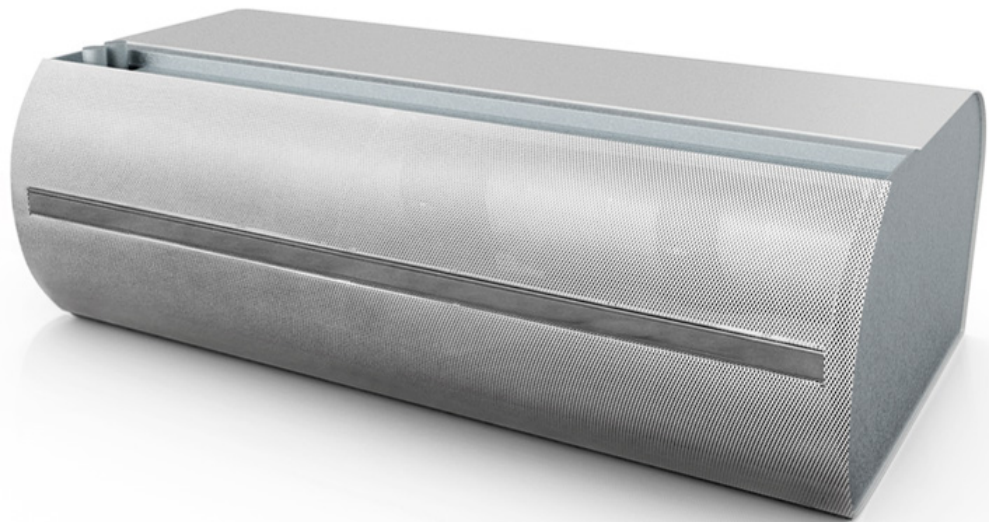
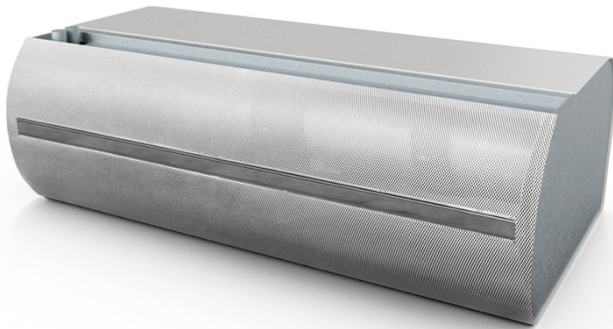

TABLE OF CONTENTS

Grand.....	457
Dimensions.....	457
Grand types.....	458
Control.....	460
Chaining example.....	461
Installation and assembly.....	462
Accessories.....	462
Ordering key.....	462
Other accessories.....	463
Wiring diagram.....	465
Ordering key.....	471

GRAND
BASIC FEATURES

- Lengths: 1; 1.5; 2 and 2.5 m
- Air flow up to 5090 m³/h (ISO 27 327-1)
- Very low noise level
- FACE 2 in 1 – suction grille + filter = 2 in 1
- Universal interface for control module connection (BA, CO, SU)
- Easy installation and service
- Wireless control option
- Standard colour RAL 9010 (any RAL – based colours may be provided on customer's request)
- The Grand is an extraordinary high-performance and visually attractive comfortable air curtain for use in representative premises, such as banks, luxury shops, shopping centres, airports and administrative buildings with a recommended installation height up to 5 m.
- The air curtain shall be installed indoor in a dry area with ambient temperatures ranging from 0 °C up to +35 °C and relative humidity of up to 80%. It is designed for conveying air free of rough dust, grease, chemical fumes, and other impurities. IP rating of the air curtain is IP 20. The air curtain project shall always be developed by the HVAC designer.

PRIMARY PARAMETERS

- Air curtains with electric heater are fitted with automatic heat thermostat and emergency thermostat with manual reset. The warm-water exchangers are designed for the maximum operating water temperature of +100 °C and maximum operating pressure of 1.6 MPa.

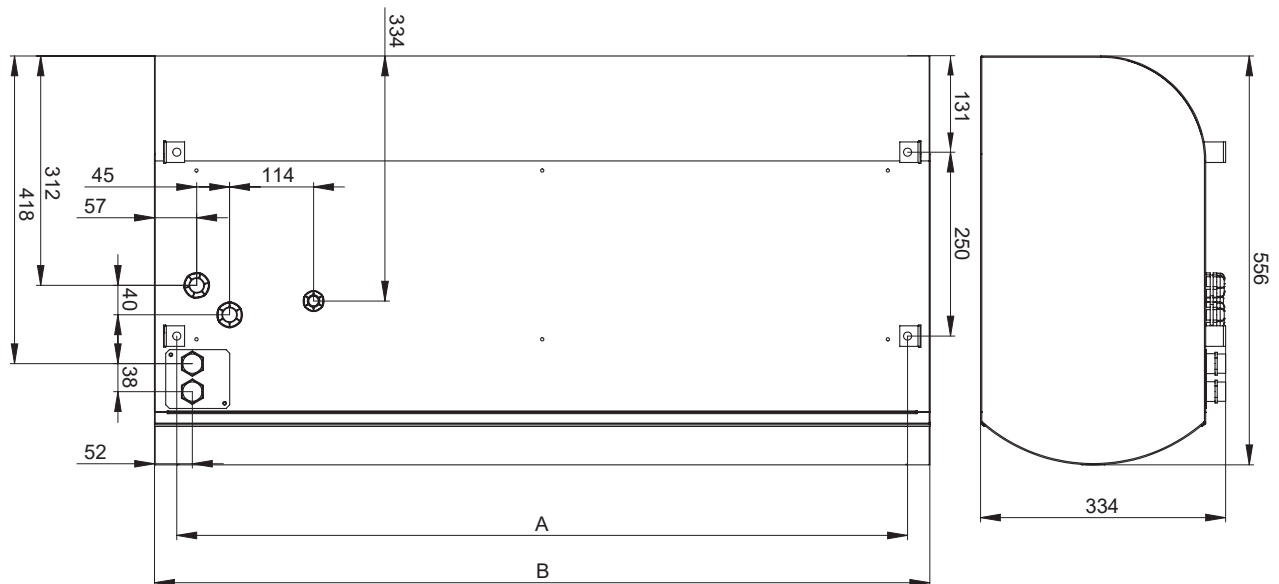
DIMENSIONS

Type	Spacing of installation holes A [mm]	Width B [mm]
GRAND-xx-10	994	1054
GRAND-xx-15	1494	1554
GRAND-xx-20	1994	2054
GRAND-xx-25	2394	2454

AIR CURTAINS GRAND / CASSETTE/ SONATA

Type	Recom- mended installation height [m]	Air output [m ³ /h] *1			Acoustic pressure at 3m [dB(A)]*2			Sound power [dB(A)]*3	Heater power output [kW]	Total con- sumption [V/A]	Motor con- sumption [W/A]	Weight [kg]*5
		Speed 3	Speed 2	Speed 1	Speed 3	Speed 2	Speed 1					
GRAND-40-10-N-	4,0	1626	1182	813	56,0	47,9	39,8	73,5	-	-	230/2,25	42
GRAND-40-15-N-	4,0	2513	1774	1256	58,7	50,9	43,2	76,2	-	-	230/3,50	59
GRAND-40-20-N-	4,0	3362	2328	1626	59,7	51,8	43,8	77,2	-	-	230/4,70	76
GRAND-40-25-N-	4,0	4065	2956	2106	60,8	53,4	44,8	78,3	-	-	230/5,60	93
GRAND-40-10-E10-	4,0	1589	1145	813	56,0	47,9	39,8	73,5	9,5	400/13,7	230/2,25	46
GRAND-40-15-E15-	4,0	2476	1700	1219	58,7	50,9	43,2	76,2	15	400/21,7	230/3,50	63
GRAND-40-20-E19-	4,0	3362	2291	1589	59,7	51,8	43,8	77,2	19	400/27,5	230/4,70	81
GRAND-40-25-E25-	4,0	3991	2919	2069	60,8	53,4	44,8	78,3	24,5	400/35,4	230/5,60	99
GRAND-40-10-W-	4,0	1552	1109	776	55,8	47,9	39,7	73,3	16,97*4	-	230/2,25	48
GRAND-40-15-W-	4,0	2439	1663	1182	57,6	49,4	41,6	75,1	38,47*4	-	230/3,50	65
GRAND-40-20-W-	4,0	3252	2180	1552	59,3	51,0	42,9	76,8	52,64*4	-	230/4,70	83
GRAND-40-25-W-	4,0	3880	2734	1884	60,6	52,7	45,4	78,1	65,46*4	-	230/5,60	97
GRAND-50-10-N-	5,0	2303	1656	1172	59,6	51,7	43,6	77,1	-	-	230/3,30	48
GRAND-50-15-N-	5,0	3353	2424	1737	60,0	52,1	44,2	77,5	-	-	230/4,60	64
GRAND-50-20-N-	5,0	4161	2990	2101	60,3	52,6	44,5	77,9	-	-	230/5,55	80
GRAND-50-25-N-	5,0	5090	3636	2666	61,1	53,4	45,6	78,6	-	-	230/6,90	98
GRAND-50-10-E10-	5,0	2262	1616	1131	59,6	51,7	43,6	77,1	9,5	400/13,7	230/3,30	53
GRAND-50-15-E15-	5,0	3272	2384	1697	60,0	52,1	44,2	77,5	15	400/21,7	230/4,60	68
GRAND-50-20-E19-	5,0	4080	2949	2060	60,3	52,6	44,5	77,9	19	400/27,5	230/5,55	86
GRAND-50-25-E25-	5,0	4888	3555	2586	61,1	53,4	45,6	78,6	24,5	400/35,4	230/6,90	110
GRAND-50-10-W-	5,0	2222	1576	1115	59,1	51,4	42,9	76,6	20,80*4	-	230/3,30	55
GRAND-50-15-W-	5,0	3151	2182	1616	59,7	52,2	43,9	77,2	43,87*4	-	230/4,60	70
GRAND-50-20-W-	5,0	3878	2788	1939	60,2	52,6	44,8	77,7	56,21*4	-	230/5,55	88
GRAND-50-25-W-	5,0	4808	3434	2424	60,7	53,3	45,5	78,2	72,12*4	-	230/6,90	108

*1 Air flow volume according ISO27327-1

*2 Acoustic pressure values at 3 and 5 m distance for maximum speed. Directional factor: Q=2.

*3 Sound power (LWA) measurements according to ISO 27327-2.

*4 Intake air temperature +18°C, at maximum heating level and highest fan speed.

*5 Weight without regulation.

Air curtain type	Air capacity [m ³ /h]	Heater power [kW]*2 *3	Temperature increase* Δt [°C]
GRAND-40-10-E10-	1589	9,5	13,19
GRAND-40-15-E15-	2476	15	13,36
GRAND-40-20-E19-	3362	19	12,46
GRAND-40-25-E25-	3391	24,5	13,54
GRAND-50-10-E10-	2262	9,5	10,12
GRAND-50-15-E15-	3272	15	11,05
GRAND-50-20-E19-	4080	19	11,23
GRAND-50-25-E25-	4888	24,5	12,08

* At the maximum air flow and maximum heater power

*2 Air curtains with BA and CO control modules has heating steps divided 50% / 100%

*3 Air curtains with SU control module has stepless heating

Water exchanger parameters for water temperature gradient of 60/40 °C

Type	Air flow [m ³ /h]	Heat output [kW]	Outlet temperature [°C]	Water flow [l/s]	Pressure loss [kPa]
GRAND-40-10-W-	1552	8,21	30	0,10	1,33
GRAND-40-15-W-	2439	18,72	36	0,22	2,57
GRAND-40-20-W-	3252	25,83	37	0,31	3,49
GRAND-40-25-W-	3880	32,13	37	0,38	5,47
GRAND-50-10-W-	2222	10,00	30	0,12	1,79
GRAND-50-15-W-	3151	21,23	35	0,25	2,94
GRAND-50-20-W-	3878	27,48	36	0,33	3,83
GRAND-50-25-W-	4808	35,22	37	0,42	6,34

* Temperature of intake air: +18 °C

Water exchanger parameters for water temperature gradient of 70/50 °C

Type	Air flow [m ³ /h]	Heat output [kW]	Outlet temperature [°C]	Water flow [l/s]	Pressure loss [kPa]
GRAND-40-10-W-	1552	11,05	35	0,13	2,09
GRAND-40-15-W-	2439	25,15	43	0,30	3,54
GRAND-40-20-W-	3252	34,60	43	0,41	5,48
GRAND-40-25-W-	3880	43,03	44	0,51	8,82
GRAND-50-10-W-	2222	13,50	34	0,16	2,88
GRAND-50-15-W-	3151	28,58	42	0,34	4,08
GRAND-50-20-W-	3878	36,86	43	0,44	6,06
GRAND-50-25-W-	4808	47,25	44	0,56	10,30

* Temperature of intake air: +18 °C

Water exchanger parameters for water temperature gradient of 80/60 °C

Type	Air flow [m ³ /h]	Heat output [kW]	Outlet temperature [°C]	Water flow [l/s]	Pressure loss [kPa]
GRAND-40-10-W-	1552	13,97	40	0,17	3,04
GRAND-40-15-W-	2439	31,72	49	0,38	4,58
GRAND-40-20-W-	3252	43,52	50	0,52	7,93
GRAND-40-25-W-	3880	54,13	52	0,64	12,96
GRAND-50-10-W-	2222	17,09	38	0,20	4,24
GRAND-50-15-W-	3151	36,12	48	0,43	5,31
GRAND-50-20-W-	3878	46,42	49	0,55	8,82
GRAND-50-25-W-	4808	59,54	51	0,71	15,26

* Temperature of intake air: +18 °C

Water exchanger parameters for water temperature gradient of 90/70 °C

Type	Air flow [m ³ /h]	Heat output [kW]	Outlet temperature [°C]	Water flow [l/s]	Pressure loss [kPa]
GRAND-40-10-W-	1552	16,97	45	0,20	4,19
GRAND-40-15-W-	2439	38,47	56	0,46	5,72
GRAND-40-20-W-	3252	52,64	57	0,63	10,90
GRAND-40-25-W-	3880	65,46	59	0,78	17,98
GRAND-50-10-W-	2222	20,80	43	0,25	5,92
GRAND-50-15-W-	3151	43,87	55	0,52	6,66
GRAND-50-20-W-	3878	56,21	57	0,67	12,19
GRAND-50-25-W-	4808	72,12	58	0,86	21,29

* Temperature of intake air: +18 °C



GRAND CASSETTE

BASIC FEATURES

- Lengths: 1; 1.5; 2; 2.5 m
- Air flow up to 5084 m³/h (ISO 27 327-1)
- Universal interface for AirGENIO control module connection (BA, CO, SU)
- FACE 2 in 1 – suction grille + filter = 2 in 1
- Low noise– Easy installation and service
- Standard colour RAL 9016 (any RAL – based colours may be provided on customer's request)

PRIMARY PARAMETERS

- Discrete and high-performance recessed air curtain for use in entrance areas of banks, administrative centres, luxury boutiques, shopping centres and airport halls with a recommended installation height up to 5 m.
- The air curtain shall be installed indoor in a dry area with ambient temperatures ranging from +5 °C up to +40 °C and relative humidity of up to 80 %. It is designed for conveying air free of fine dust, grease, chemical fumes, and other impurities. IP rating of the air curtain is IP 20. The air curtain project shall always be developed by the HVAC designer.

DIMENSIONS

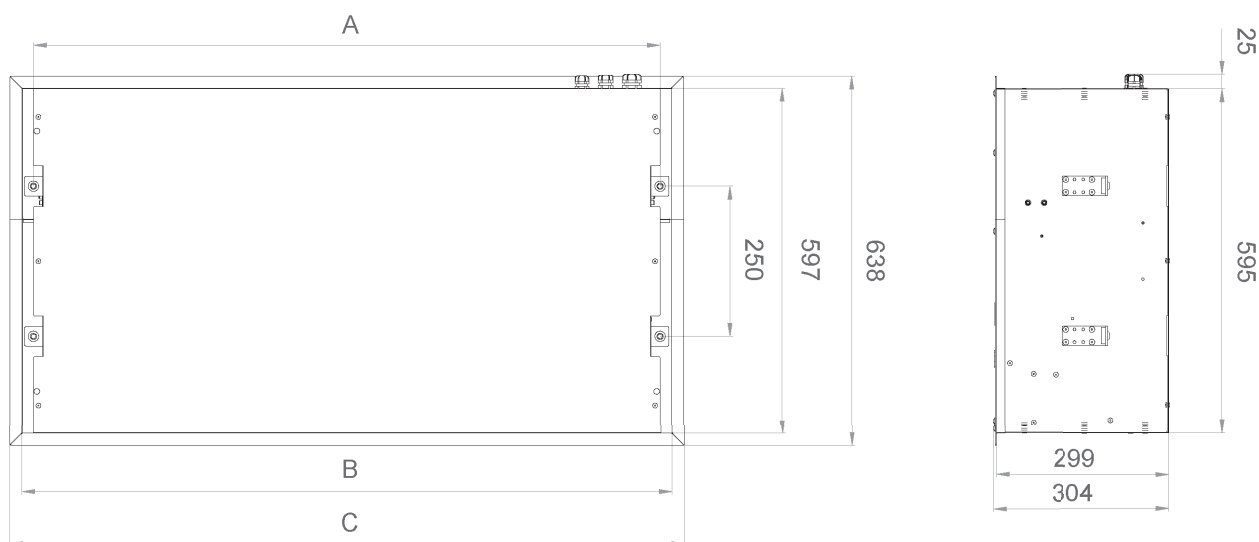

Type	Recommended installation height [m]	Air output [m ³ /h] *1			Acoustic pressure at 3m [dB(A)]*2			Sound power [dB(A)]*3	Heater power output [kW]	Total consumption [V/A]	Motor consumption [W/A]	Weight [kg]*5
		Speed 3	Speed 2	Speed 1	Speed 3	Speed 2	Speed 1					
GRAND C-40-10-N-	4,0	1793	1225	822	58,3	50,3	42,3	75,8	-	-	230/2,75	37,5
GRAND C-40-15-N-	4,0	2591	1770	1193	60,2	52,1	42,8	77,8	-	-	230/4,0	51,0
GRAND C-40-20-N-	4,0	3476	2402	1659	61,5	53,7	44,6	79	-	-	230/5,3	66,0
GRAND C-40-25-N-	4,0	4313	2899	1959	62,7	54,4	45,3	80,2	-	-	230/6,5	80,0
GRAND C-40-10-E10-	4,0	1778	1217	814	57,9	49,6	41,5	75,5	9,4	400/16,3	230/2,75	39,5
GRAND C-40-15-E15-	4,0	2552	1738	1130	60,2	52,1	42,6	77,7	15	400/26,1	230/4,0	54,5
GRAND C-40-20-E19-	4,0	3444	2307	1485	61,2	53,3	44,3	78,8	19	400/32,4	230/5,3	71,0
GRAND C-40-25-E25-	4,0	4187	2844	1880	62,8	54,5	45,3	80,3	24,5 T	400/42,2	230/6,5	85,0
GRAND C-40-10-W-	4,0	1691	1146	758	57,5	49,6	41,2	75	24,8*2	230/2,75	230/4,0	41,0
GRAND C-40-15-W-	4,0	2449	1643	1082	59,6	51,6	42,3	77,1	38,8*2	230/4,0	230/5,3	56,0
GRAND C-40-20-W-	4,0	3381	2267	1422	61	53,3	44,1	78,5	52,6*2	230/5,3	230/6,5	73,0
GRAND C-40-25-W-	4,0	4061	2765	1825	62,5	54,4	45,3	80	62,3*2	230/6,5	230/5,60	87,0
GRAND C-50-10-N-	5,0	2517	1768	1217	61,9	54,2	45,2	79,5	-	-	230/4,8	42,0
GRAND C-50-15-N-	5,0	3468	2359	1625	63,0	55,4	46,2	80,5	-	-	230/6,3	56,5
GRAND C-50-20-N-	5,0	4393	3151	2084	64,2	56,5	47,4	81,7	-	-	230/7,9	71,0
GRAND C-50-25-N-	5,0	5084	3701	2501	65,7	58,3	49,2	83,2	-	-	230/9,7	84,0
GRAND C-50-10-E10-	5,0	2467	1742	1175	61,2	53,5	44,6	78,7	9,4	400/18,8	230/4,7	44,0
GRAND C-50-15-E15-	5,0	3401	2343	1567	62,7	55,2	46,0	80,2	15	400/28,3	230/6,2	60,0
GRAND C-50-20-E19-	5,0	4318	3051	2042	64,0	56,3	47,3	81,5	19	400/35,4	230/7,8	75,5
GRAND C-50-25-E25-	5,0	5018	3626	2426	65,8	58,2	49,1	83,3	24,5	400/45,2	230/9,4	90,0
GRAND C-50-10-W-	5,0	2334	1684	1134	61,2	54,0	45,3	78,7	29,1 ²	230/4,7	230/4,7	45,5
GRAND C-50-15-W-	5,0	3251	2343	1567	62,5	55,4	46,4	80	44,6 ²	230/6,2	230/6,2	61,0
GRAND C-50-20-W-	5,0	4226	3084	2034	63,7	56,4	47,5	81,2	57,0 ²	230/7,8	230/7,8	77,0
GRAND C-50-25-W-	5,0	4885	3526	2334	65,6	58,7	49,6	83,1	67,3 ²	230/9,4	230/9,4	91,5

*1 Air flow volume according ISO27327-1

*2 Acoustic pressure values at 3 and 5 m distance for maximum speed. Directional factor: Q=2.

*3 Sound power (LWA) measurements according to ISO 27327-2.

*4 Intake air temperature +18°C, at maximum heating level and highest fan speed.

*5 Weight without regulation.

Air curtain type	Air capacity [m ³ /h]	Heater power [kW]*2 *3	Temperature increase* Δt [°C]
GRAND C-40-10-E10-	1778	9,4	15,7 ^{*1}
GRAND C-40-15-E15-	2552	15	17,5 ^{*1}
GRAND C-40-20-E19-	3444	19	16,4 ^{*1}
GRAND C-40-25-E25-	4187	24,5	17,4 ^{*1}
GRAND C-50-10-E10-	2467	9,4	11,3 ^{*1}
GRAND C-50-15-E15-	3401	15	13,1 ^{*1}
GRAND C-50-20-E19-	4318	19	13 ^{*1}
GRAND C-50-25-E25-	5018	24,5	14,5 [*]

* At the maximum air flow and maximum heater power

*2 Air curtains with BA and CO control modules has heating steps divided 50% / 100%

*3 Air curtains with SU control module has stepless heating

Water exchanger parameters for water temperature gradient of 60/40 °C

Type	Air flow [m ³ /h]	Heat output [kW]	Outlet temperature [°C]	Water flow [l/s]	Pressure loss [kPa]
GRAND C-40-10-W-	1691	9,3	34,4	0,11	4
GRAND C-40-15-W-	2449	14,9	36,1	0,66	8
GRAND C-40-20-W-	3381	20	35,7	0,24	6
GRAND C-40-25-W-	4061	23,7	35,4	0,28	5
GRAND C-50-10-W-	2334	11,3	32,5	0,14	4
GRAND C-50-15-W-	3251	17,7	34,3	0,21	9
GRAND C-50-20-W-	4226	23	34,3	0,27	7
GRAND C-50-25-W-	4885	26,5	34,2	0,32	5

* Temperature of intake air: +18 °C

Water exchanger parameters for water temperature gradient of 70/50 °C

Type	Air flow [m ³ /h]	Heat output [kW]	Outlet temperature [°C]	Water flow [l/s]	Pressure loss [kPa]
GRAND C-40-10-W-	1691	13,1	41,1	0,16	5
GRAND C-40-15-W-	2449	20,4	42,9	0,25	11
GRAND C-40-20-W-	3381	27,6	42,4	0,33	9
GRAND C-40-25-W-	4061	32,8	42,1	0,4	8
GRAND C-50-10-W-	2334	16	38,4	0,19	7
GRAND C-50-15-W-	3251	24,4	40,5	0,29	16
GRAND C-50-20-W-	4226	31,9	40,4	0,38	11
GRAND C-50-25-W-	4885	36,9	40,6	0,45	8

* Temperature of intake air: +18 °C

Water exchanger parameters for water temperature gradient of 80/60 °C

Type	Air flow [m ³ /h]	Heat output [kW]	Outlet temperature [°C]	Water flow [l/s]	Pressure loss [kPa]
GRAND C-40-10-W-	1691	16,8	47,7	0,2	8
GRAND C-40-15-W-	2449	25,9	49,5	0,32	16
GRAND C-40-20-W-	3381	35,1	49	0,43	13
GRAND C-40-25-W-	4061	41,8	48,7	0,51	10
GRAND C-50-10-W-	2334	20,6	44,4	0,25	9
GRAND C-50-15-W-	3251	31,1	46,5	0,37	22
GRAND C-50-20-W-	4226	40,6	46,7	0,49	15
GRAND C-50-25-W-	4885	47,1	46,8	0,57	12

* Temperature of intake air: +18 °C

Water exchanger parameters for water temperature gradient of 90/70 °C

Type	Air flow [m ³ /h]	Heat output [kW]	Outlet temperature [°C]	Water flow [l/s]	Pressure loss [kPa]
GRAND C-40-10-W-	1691	20,5	54,2	0,25	9
GRAND C-40-15-W-	2449	31,3	56,1	0,38	22
GRAND C-40-20-W-	3381	42,6	55,6	0,52	16
GRAND C-40-25-W-	4061	50,7	55,3	0,62	13
GRAND C-50-10-W-	2334	25,2	50,3	0,31	13
GRAND C-50-15-W-	3251	37,7	52,6	0,46	28
GRAND C-50-20-W-	4226	49,3	52,8	0,6	21
GRAND C-50-25-W-	4885	57,3	53,0	0,7	17

* Temperature of intake air: +18 °C

CONTROL

- The Grand air curtains are produced with universal interface for control module connection. There are three types of control modules available (BA, CO and SU). Control module is an required accessorie for each air curtain.
- Additional change of control system is available. Control module is connected with air curtain by quick connection sockets. The basic differences among individual control module types are given in table underneath.



	BASIC SONATA EVO-BA	COMFORT SONATA EVO-CO	SUPERIOR SONATA EVO-SU
Type of controller / Mode	Manual / Manual	Touch screen / Manual or Auto*	Touch screen / Manual or Auto
Regulation of air output	3 speeds	3 speeds	3 speeds (AC) 10 speeds (EC)
Regulation of electric heater	OFF / Level1 / Level2	OFF / Level1 / Level2	YES (PWM)
Regulation of water heater	ON/OFF	ON/OFF	0-10V
Antifreeze protection of LPHW	NO	NO	YES
Possibility of connecting a door contact	YES (230V)	YES (12V)	YES (12V)
External control	NO	YES	YES
Temperature measurement	YES (Room thermostat)	YES (Room thermostat)	Yes (NTC)**
Chaining air curtains	NO	YES – max 10+1 pcs	YES – max 10+1 pcs
Indication of selected function	YES	YES (Display)	YES (Display)
Controller connection to air curtain	Power wire	Communication cable (UTP)	Communication cable (UTP)
Self learning mode	NO	NO	YES
BMS connection	NO	Modbus RTU	Modbus RTU, Modbus TCP
Error contact	NO	YES	YES
2nd control panel ready	NO	YES	YES

*) Auto mode only ON/OFF with connected Room thermostat

***) Temperature sensor included in standard. Temperature shown on display

CHAINING EXAMPLE

COMFORT / SUPERIOR

- Global Door contact function active

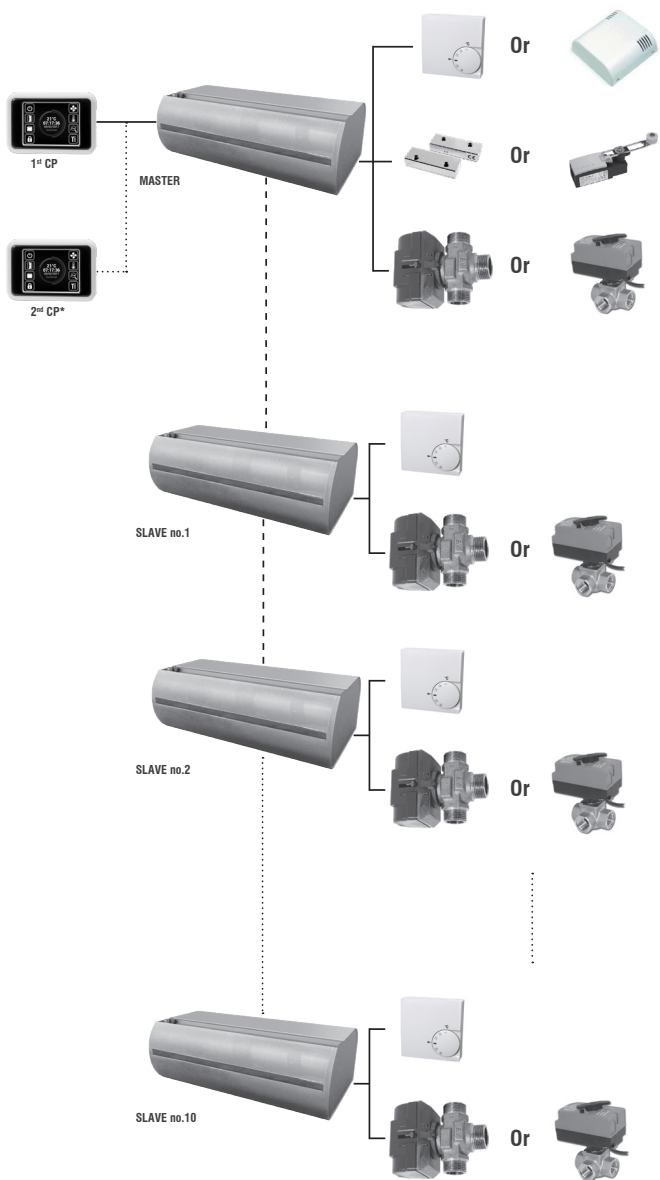

COMFORT / SUPERIOR

- Global Door contact function not active

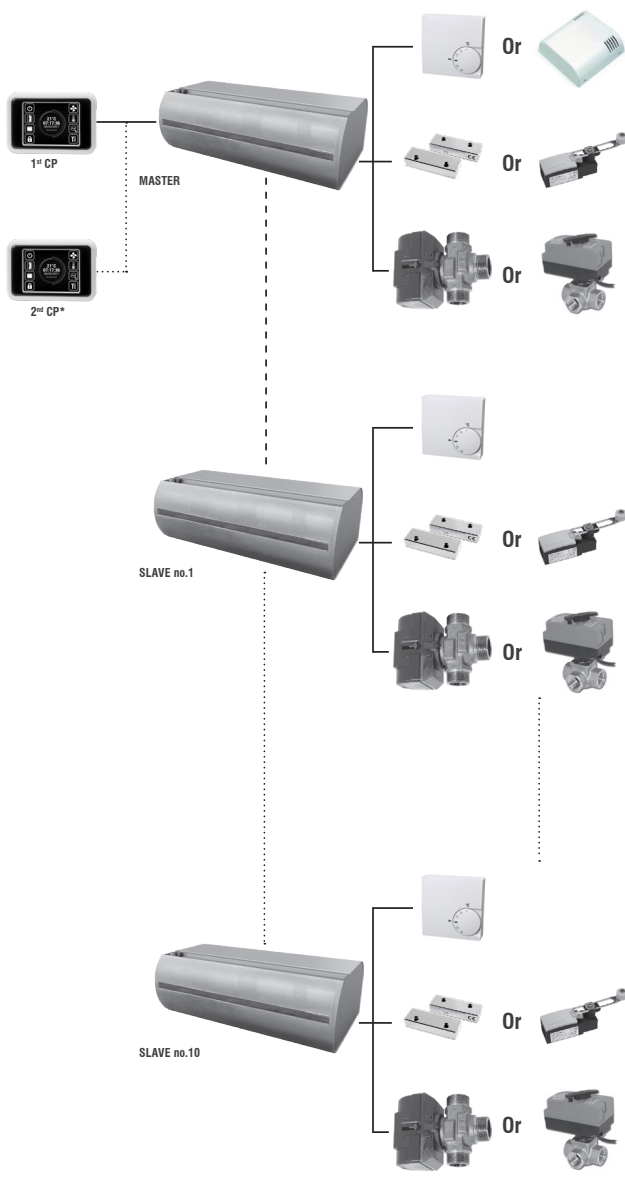

*) Optional accessories

INSTALLATION AND ASSEMBLY

- The air curtain shall be installed in a horizontal position only.
- The air curtain shall be located as close to the top edge of the doorway as possible, see figure.
- To ensure a correct function it is recommended that the air curtain overlaps the doorway by 100 mm on both sides.
- Correct operation of the air curtain requires that specified distances from the surrounding objects are observed, see figure.
- Position of the heating water and power supply connections shall be taken into consideration during installation.
- Suspension holders are used for installing the air curtains see ACCESSORIES.

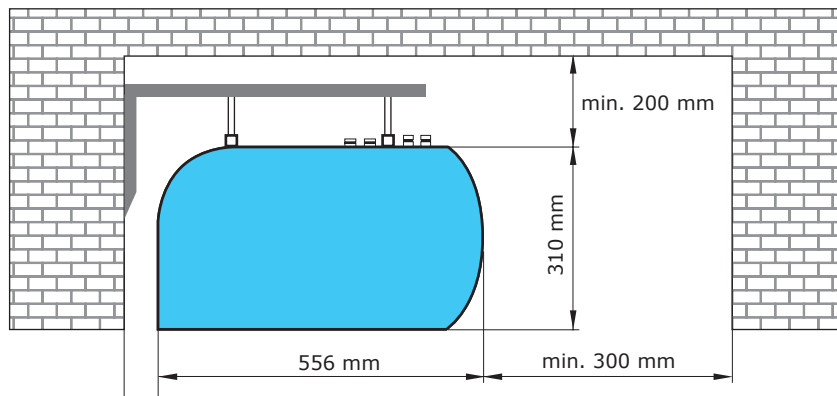

ACCESSORIES

REQUIRED ACCESSORIES

These accessories are required to make the curtain functional.

Control module

- A control module is an required accessorie for air curtain and shall be ordered for each air curtain. Control panel is included in delivery of control module. The ordering key for control modules is provided below.
- Communication cable has to be ordered separately as an optional accessorie.

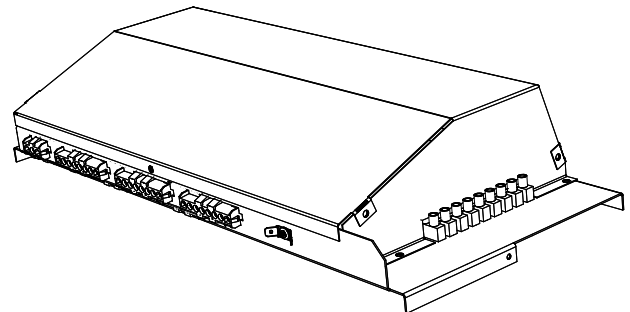

ORDERING KEY

Air curtain	GRAND	- SU	- E	- MA	- AC
	GRAND C				
BA – Basic control (mechanical)					
CO – Comfort control (touch screen)					
SU – Superior control (touch screen)					
N – without heating regulation					
E – with electric heater regulation					
W – with water heater regulation					
SL – SLAVE (only for CO, SU)					
MA – MASTER (only for CO, SU)					
AC – AC motor					

OTHER ACCESSORIES



Thermostatic valve TV-1-1/1
TV-1-1/1



Timer with a weekly program
SH-TM-848

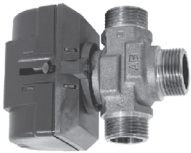

Zone valve with servo drive ZV-3
ZV-3 (for control BA, CO)



OpenEnd module (Control module for BMS)
OE-M-AC3 (for control BA)



Water valve
RT-3-11 (KVS 11)
RT-3-15 (KVS 15)
(for control BA, CO)



Room thermostat
TER-P



Water valve (0-10V)
ZV-3-24V-XX
(for control SU)



Room thermostat
TER-P



Mixing node
SMU2-230-xx (for control BA, CO)
SMU2-024-xx (for control SU)



Room temperature sensor
CT-ROOM (for control SU)



Mechanical door switch (230V)
DS



Magnetic door contact (12V)
DK-1



Magnetic door contact (12V) in a metal housing with higher protection against mechanical damage
DK-B-3

	BASIC SONATA EVO-BA	COMFORT SONATA EVO-CO	SUPERIOR SONATA EVO-SU
DS	●	●	●
DK-1	●	●	●
DK-B-3	●	●	●

* Recommended for industry use

OTHER ACCESSORIES

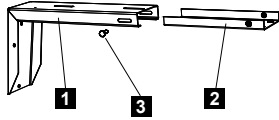

Wall mounting bracket

Bracket designed for mounting the air curtain to the wall.

- 1 Bracket
- 2 Hanging strip
- 3 Securing screw

GRAND-KONZ-STE

- for B and C air curtains (2 pcs. in package)
- wall mounting bracket

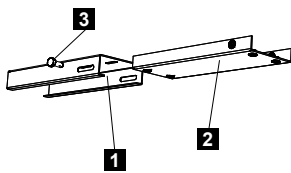

Ceiling holder

The holder is designed for attaching the air curtain to a ceiling.

- 1 Ceiling bracket
- 2 Hanging strip
- 3 Securing screw

GRAND-KONZ-STR

- for B and C air curtains (2 pcs. in package)
- ceiling holder



Exit sign for marking of emergency exits.

Suitable for all types of air curtains.

GRAND-EXIT

WIRING DIAGRAMS

- The recommended cross-section of the main power supply cables is stated in the Instruction Manual.
- All wiring diagrams provided in the technical catalog are indicative only. When assembling the product, carefully observe the nameplate ratings as well as directions and diagrams affixed directly to the product or enclosed with the product.



BASIC

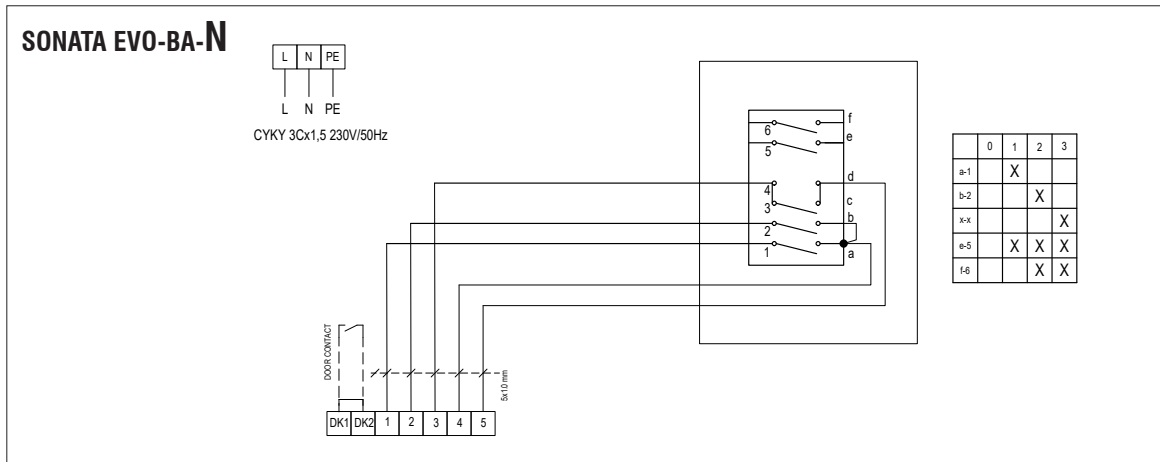
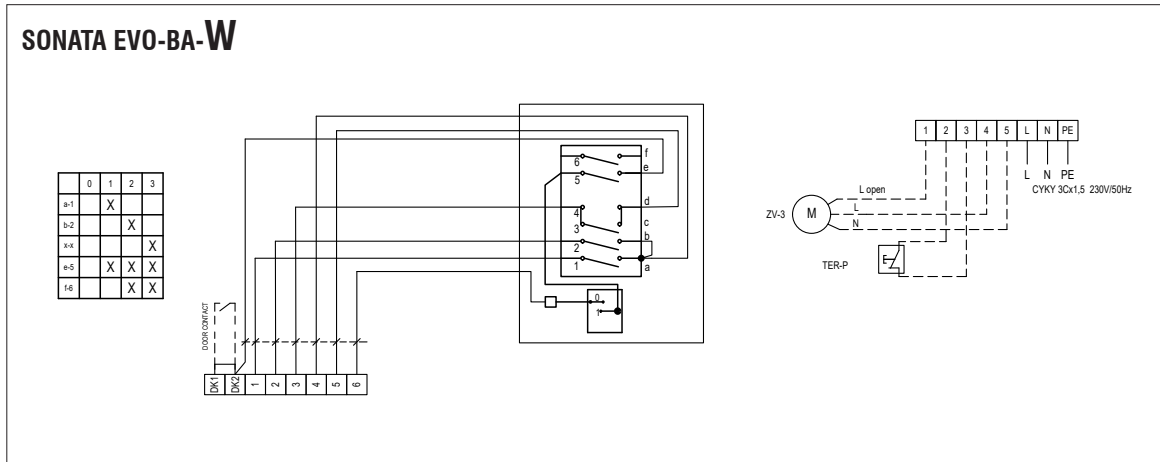
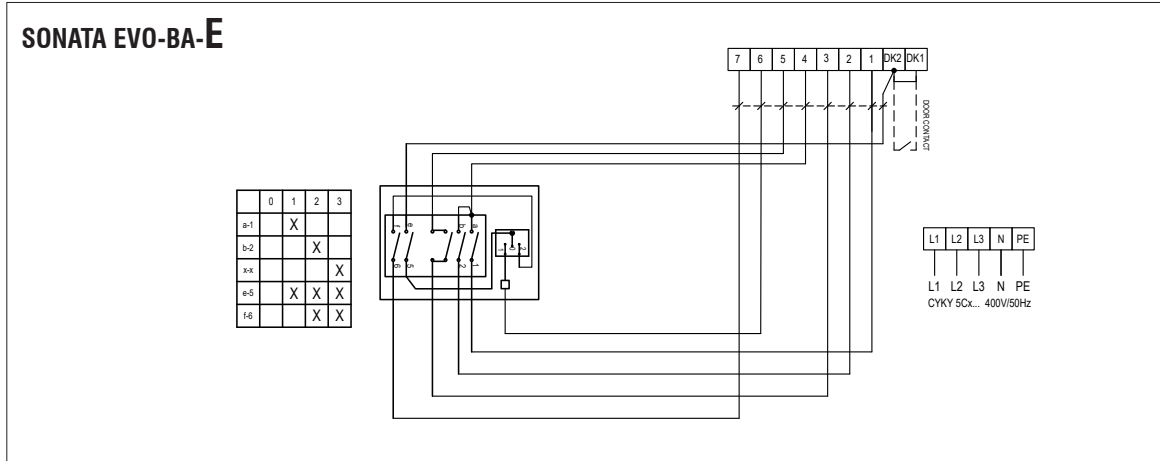

WIRING DIAGRAMS



COMFORT MASTER

SONATA EVO-CO-*E

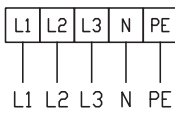

SONATA EVO-CO-*N

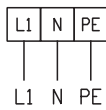

SONATA EVO-CO-*W

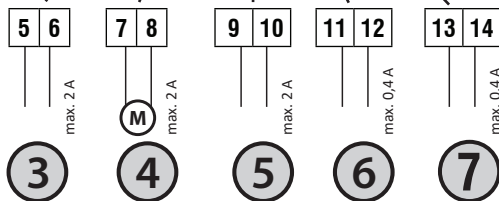
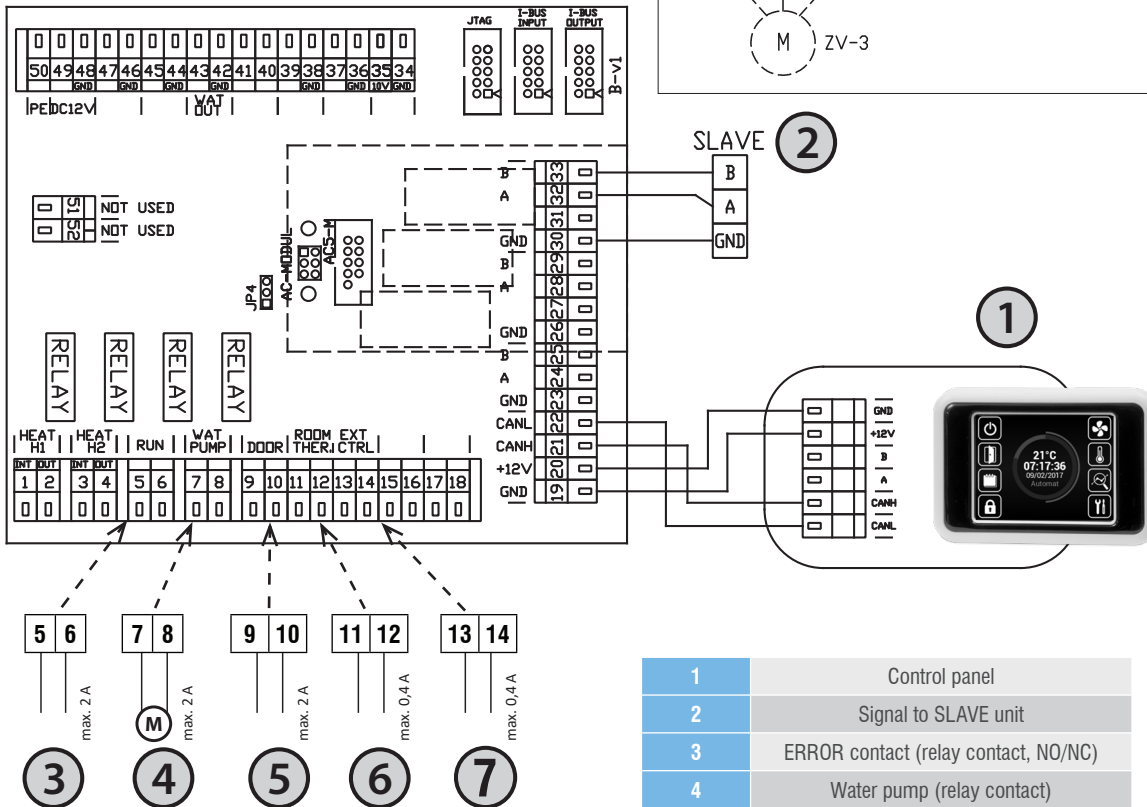
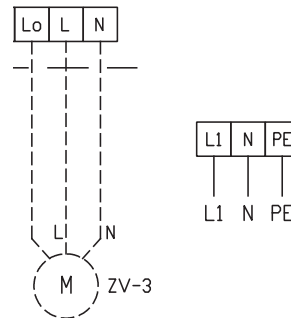

1	Control panel
2	Signal to SLAVE unit
3	ERROR contact (relay contact, NO/NC)
4	Water pump (relay contact)
5	DOOR contact (input, NO/NC)
6	Room thermostat (input, NO/NC)
7	External control (input, NO/NC)

WIRING DIAGRAMS



COMFORT SLAVE

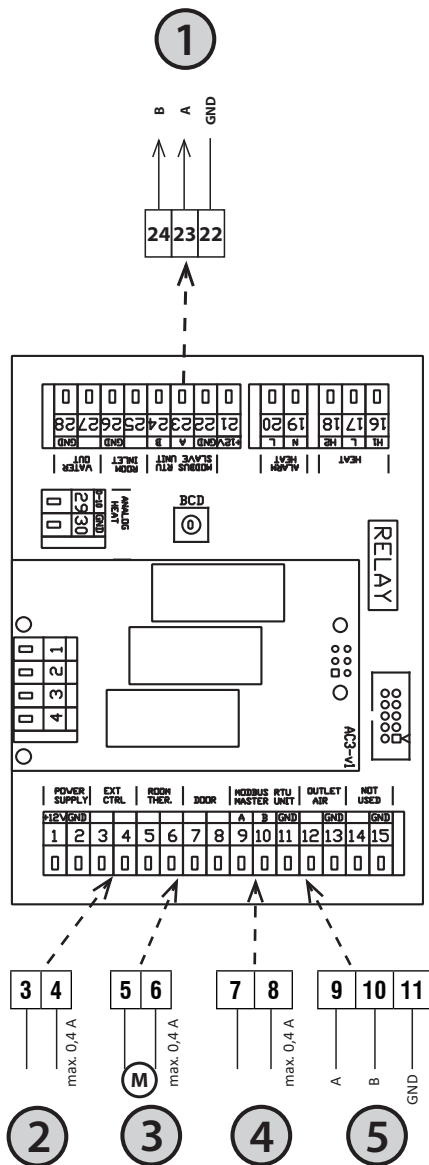
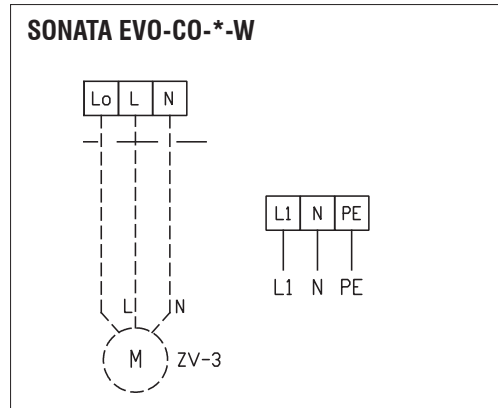
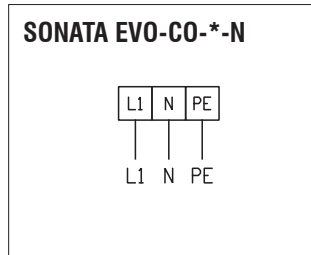
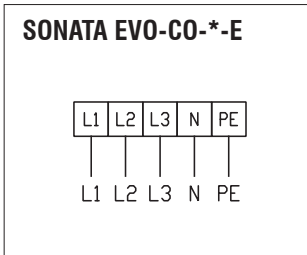

1	Signal to SLAVE unit
2	External control - ON/OFF
3	Room thermostat (input)
4	DOOR contact (input)
5	Signal from MASTER unit

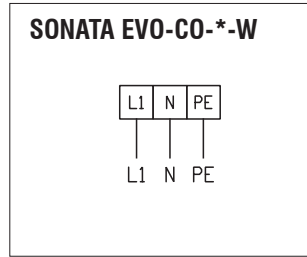
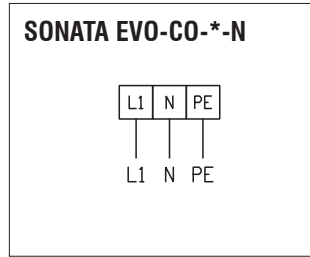
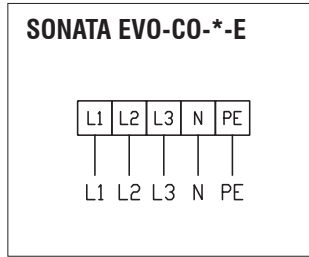
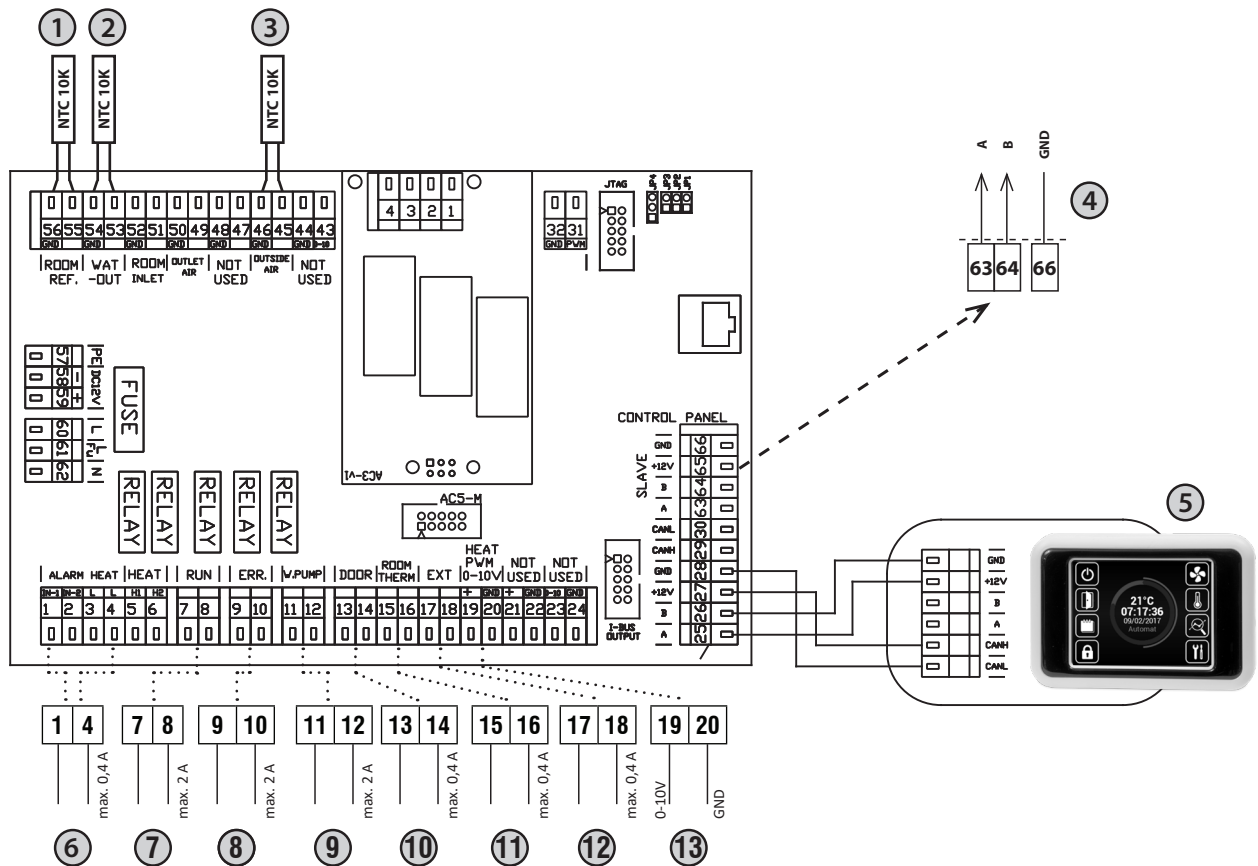
WIRING DIAGRAMS

SUPERIOR MASTER

1	Room sensor (accessories)
2	LPHW out sensor (included in delivery)
3	Outside air sensor (included in delivery)
4	Signal to SLAVE unit
5	Control panel
6	Antifreeze thermostat (NC)
7	RUN contact (relay contact, NO/NC)
8	ERROR contact (relay contact, NO/NC)
9	Water pump (relay contact)
10	DOOR contact (input, NO/NC)
11	Room thermostat (input, NO/NC)
12	External control (input, NO/NC)
13	Water valve control (0-10V)

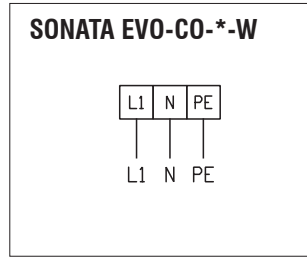
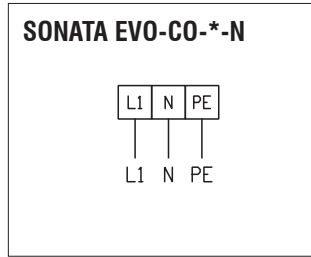
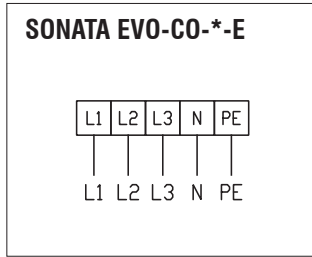
WIRING DIAGRAMS

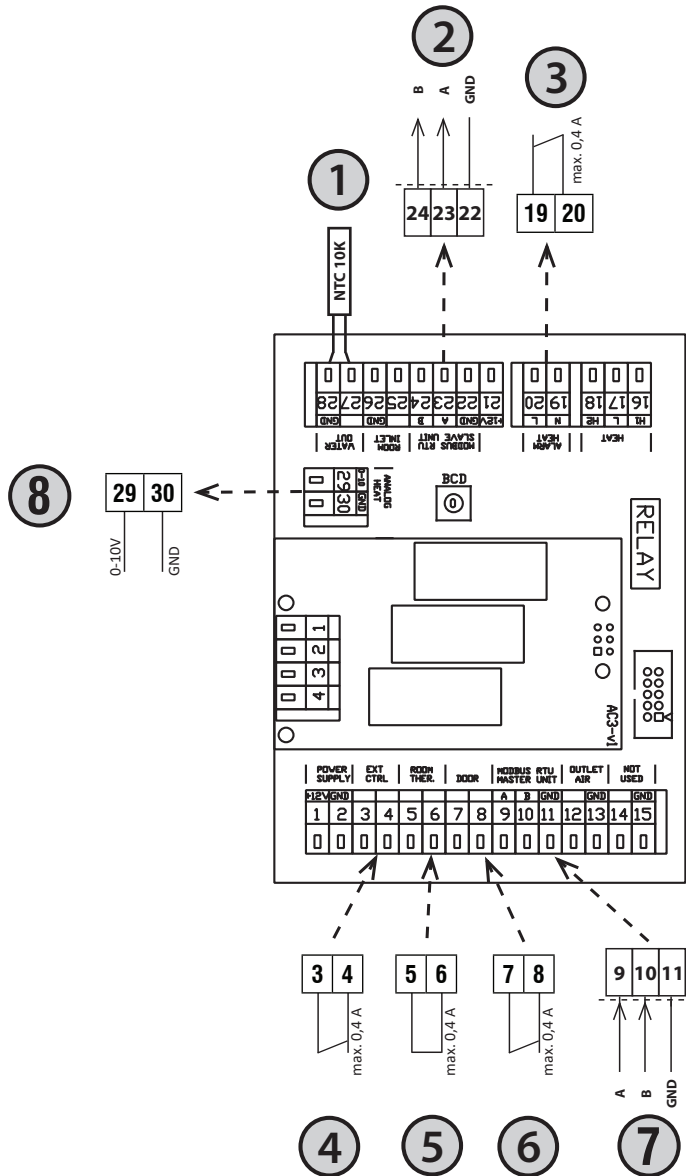

SUPERIOR SLAVE



1	LPHW out sensor (included in delivery)
2	Signal to SLAVE unit
3	Antifreeze thermostat (NC)
4	External control - ON/OFF
5	Room thermostat (input)
6	DOOR contact (input)
7	Signal from MASTER unit
8	Water valve control (0-10V)

WIRING DIAGRAMS

SUPERIOR

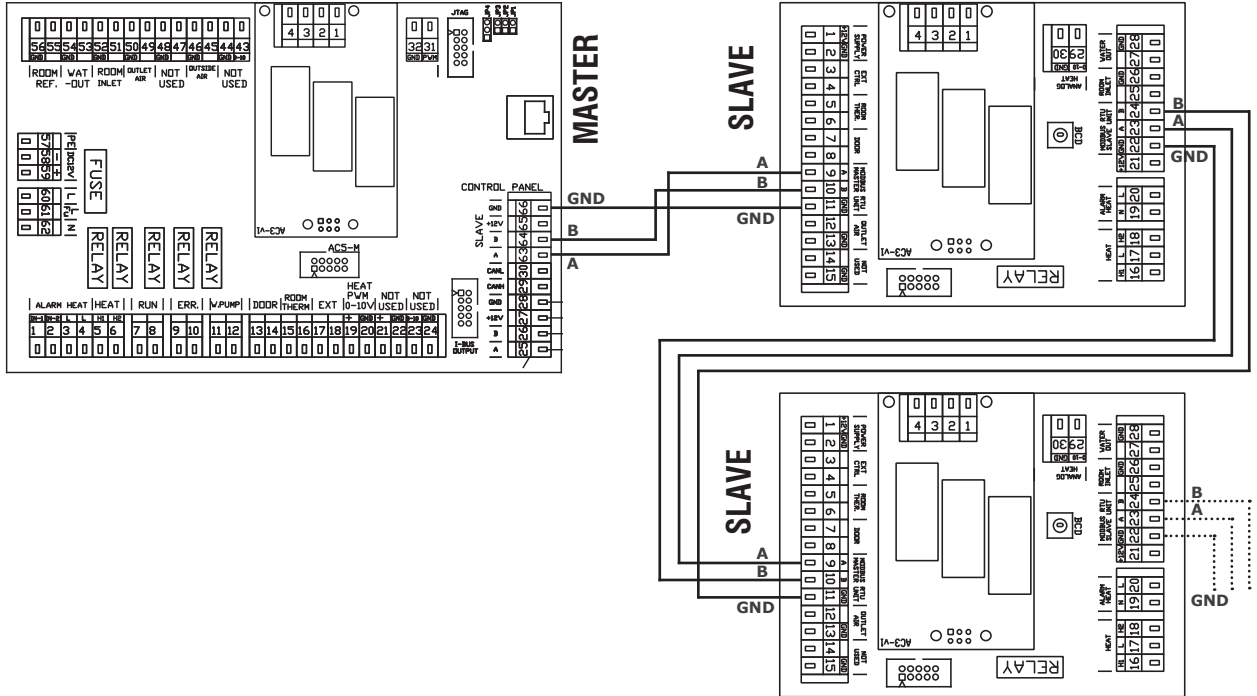

COMFORT

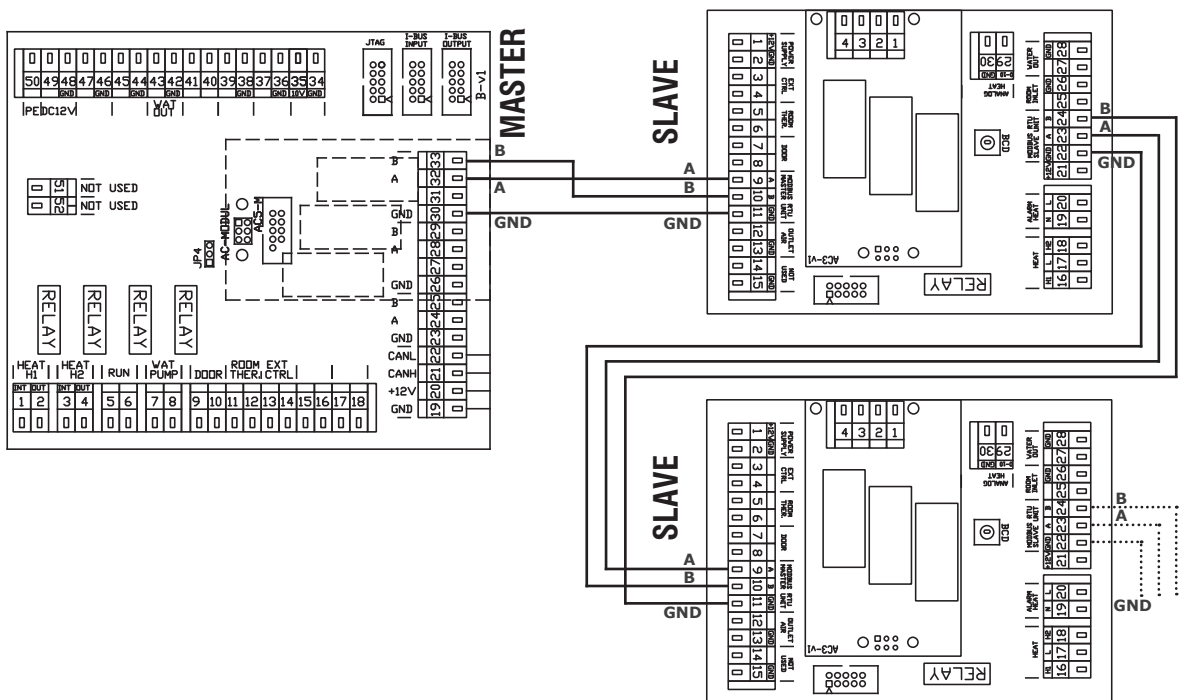

ORDERING KEY

Air curtain	GRAND	- 40	- 10	- W
	GRAND C			
40 – B Output series				
50 – C Output series				
10 – Nominal width 1000 mm				
15 – Nominal width 1500 mm				
20 – Nominal width 2000 mm				
25 – Nominal width 2500 mm				
N – Air-only				
E – Electrical heater				
W – Water heater				